



MODEL 3800
MICRO-MINIATURE INFRARED THERMOMETER SYSTEM
OPERATING MANUAL



Physical Address: 1891 North Oracle • Tucson, AZ 85705-6444

Mailing Address: P. O. Box 5276 • Tucson, AZ 85703-0276

Telephone: (520) 792-4545 • Fax: (520) 792-4546

Toll Free: (800) 422-4342

Email: info@everestinterscience.com • Website: www.EverestInterscience.com

02/08

TABLE OF CONTENTS

	<u>INFORMATION</u>	<u>PAGE</u>
Section 1	INTRODUCTION	3
	Specifications for Model 3800ZH	4
	Specifications for Model 3800ZL	5
Section 2	UNPACKING	6
Section 3	INSTALLATION	7
	3.1 Outputs	7
Section 4	MAINTENANCE	8
	4.1 Cleaning	8
Section 5	LIMITED WARRANTY INTRUCTIONS	9
	DETERMINATION OF EMISSIVITY	10
Appendix	EMISSIVITY OF TOTAL RADIATION FOR VARIOUS METALS	13

INSTRUCTION MANUAL FOR MODEL 3800 MICRO-MINIATURE INFRARED THERMOMETER SYSTEM

SECTION 1 INTRODUCTION

Thank you for purchasing an Everest Interscience Micro-Miniature Infrared Thermometer. It is a revolutionary new precision temperature measurement system housed in a stainless steel case that is only 5/8" in diameter and 2-1/4" long. There is no need for a remote transmitter to perform the linearization and signal conditioning. It is now done all in this one, miniature sensor!

The specifications for the Model 3800ZH are listed in Table 1 and the specifications for the Model 3800ZL are listed in Table 2.

We are pleased that you chose Everest's Infrared Temperature Sensor for your temperature measurement requirements. We are positive that you will find them to be fast, simple to use, dependable and reliable with repeatable accuracy.

If you have any questions about a particular application, or about the operation of your temperature sensor, do not hesitate to contact us at our Toll-Free Hot Line – (800) 422-4342. For foreign users, our telephone number is (520) 792-4545. Our facsimile number is (520) 792-4546 and our E-mail address is info@EverestInterscience.com.

To learn more about Everest's line of products, please log on to our website at www.everestinterscience.com.

Table 1

SPECIFICATIONS FOR 3800ZH MICRO-MINIATURE INFRARED THERMOMETER SYSTEM

TEMPERATURE MEASUREMENT

Scale Range:	-40°C to 1100°C or -40°F to 2000°F
Resolution:	1.0°C or 1.0°F
Accuracy:	±1% of Reading ±1.0°
Repeatability:	±1.0°C or ±2.0°F
Temperature:	All Functions in °C or °F, corresponding to voltage/current out
Noise Effective Temperature:	<1.0°C

OPTICAL CONSIDERATIONS

Optical Configuration:	Robust, aerospace-quality, double-coated Zinc Selenide Optics per Military Specification MIL-C-13508
Spectral Pass Band:	8 < Wavelengths < 14 Microns
Field of View:	2° or 15°

OPERATING CONDITIONS

Operating Environment:	-40°C to 100°C or -40°F to 200°F, up to 95% Relative Humidity, Non-Condensing
Storage Temperature:	Same as Operating Environment Temperature

GENERAL

Response Time:	Standard: .035 Second; Optional: .015 Second 10%-90%
Emissivity Compensation:	0.1 to 0.98 Settable
Operating Distance:	2 mm to 300 meters
Dimensions:	5/8" Diameter by 2-1/4" Length

ELECTRICAL INTERFACE

Power Requirements:	5V to 26V DC (Current Draw: 10 mA)
Output Signal	Standard: 4-20mA Optional: 0-5 Volt, mV (1.0mV/°C) and Type J or K Thermocouple

Everest Interscience, Inc., has a policy of continued design upgrade. Therefore, we reserve the right to change specifications without notice.

Table 2

SPECIFICATIONS FOR 3800ZL MICRO-MINIATURE INFRARED THERMOMETER SYSTEM

TEMPERATURE MEASUREMENT

Scale Range:	-40°C to 100°C or -40°F to 212°F
Resolution:	0.1°C or 0.1°F
Accuracy:	±0.5°C or ±0.5°F
Repeatability:	±0.1°C or ±0.2°F
Temperature:	All Functions in °C or °F, corresponding to voltage/current out
Noise Effective Temperature:	±0.2°C

OPTICAL CONSIDERATIONS

Optical Configuration:	Robust, aerospace-quality, double-coated Zinc Selenide Optics per Military Specification MIL-C-13508
Spectral Pass Band:	8 < Wavelengths < 14 Microns
Sighting:	Line of Sight
Field of View:	4° or 15°

OPERATING CONDITIONS

Operating Environment:	-40°C to 100°C or -40°F to 200°F, up to 95% Relative Humidity, Non-Condensing
Storage Temperature:	Same as Operating Environment Temperature

GENERAL

Response Time:	.050 Second
Emissivity Compensation:	0.1 to 0.98 Settable
Operating Distance:	2 mm to 300 meters
Dimensions:	5/8" Diameter by 2-1/4" Length

ELECTRICAL INTERFACE

Power Requirements:	5V to 26V DC (Current Draw: 10 mA)
Output Signal:	Standard: 4-20mA Optional: 0-5 Volt, mV (10.0mV/°C) and Type J or K Thermocouple

Everest Interscience, Inc., has a policy of continued design upgrade. Therefore, we reserve the right to change specifications without notice.

SECTION 2 UNPACKING

Remove the Packing List and verify that you have received all of the following equipment

1. Infrared Model 3800 Temperature Sensor
2. Cable with connector
3. Two Hex Nuts
4. Any Accessories Ordered
5. Instruction Manual
6. Calibration Certificate

If there are any questions about the contents of the shipment, please call Everest's Customer Service Department at 1-800-422-4342 or (520) 792-4545.

When you receive the shipment, inspect the container and equipment for any signs of damage. Note any evidence of rough handling in transit. Immediately report any damage to the shipping agent.

NOTE

Our carrier will not honor any claims unless all shipping materials are saved for their examination. After examining and removing contents, save packing material and carton in the event reshipment is necessary.

If any shipment has to be returned to Everest, please go on-line to get a Return Material Authorization Form at <http://www.everestinterscience.com/Forms/rmarequest.htm> or call us at the following numbers: Domestic – (800) 422-4342 Foreign – (520) 792-4545; we will provide you with an RMA Number.

SECTION 3 *INSTALLATION*

3.1 OUTPUTS

The following diagrams is wiring information for the a 4-20 mA Output.

A diagram of the connector for the 4-20 mA Output is shown below in Figure 1.

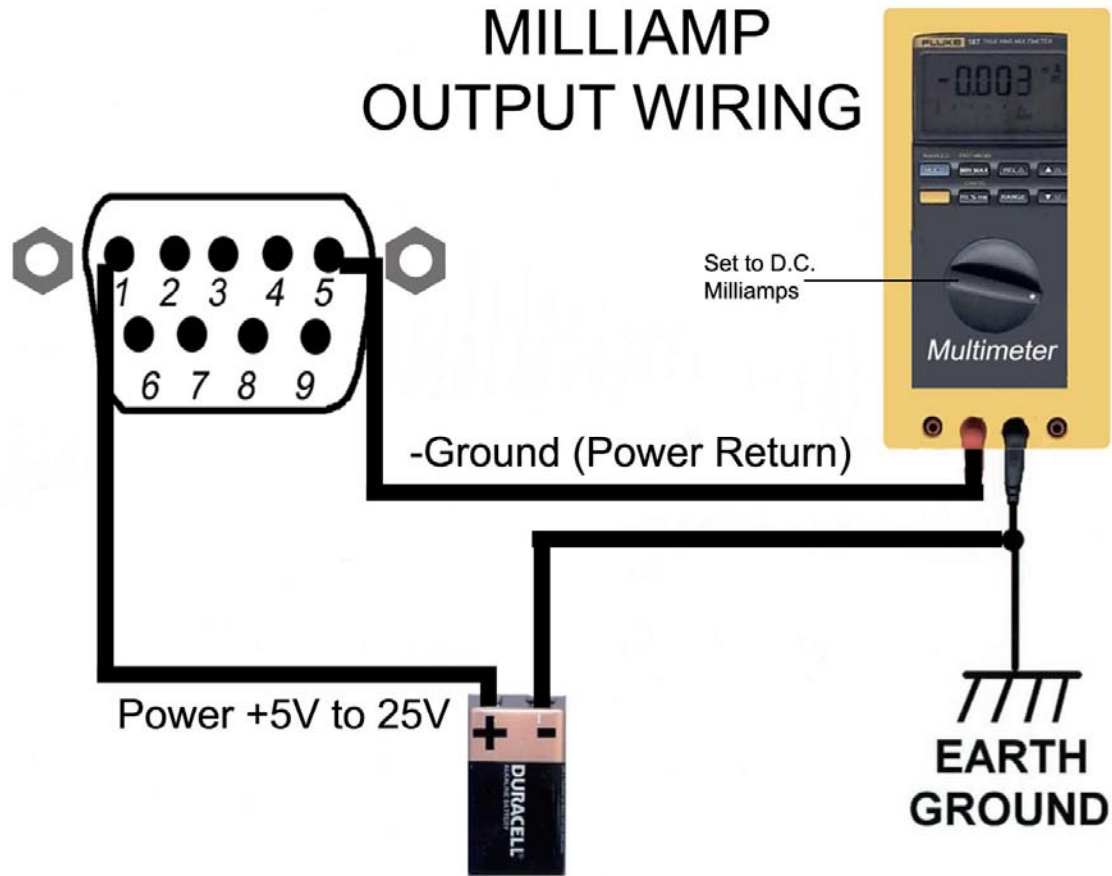

Figure 1

FORMULA HIGH TEMP:

$$\text{mA} = 4 + [0.014035087 \times (\text{°C} + 40)]$$

$$\text{°C} = [71.25 \times (\text{mA} - 4)] - 40$$

FORMULA LOW TEMP:

$$\text{mA} = 4 + [0.114285714 \times (\text{°C} + 40)]$$

$$\text{°C} = [8.75 \times (\text{mA} - 4)] - 40$$

SECTION 4 MAINTENANCE

4.1 Cleaning

The Everest Model 3800 Infrared Temperature Sensor is relatively free of maintenance. However, when impurities begin to deposit on the lens or window, use only alcohol or warm water for cleaning. Gentle cleaning, as well as cleaning with a cotton swab, is referable.

It is important not to leave any residue on the lens after cleaning. Even films that are transparent to the human eye can cause errors in accuracy.

SECTION 5 ONE-YEAR LIMITED WARRANTY SERVICE INSTRUCTIONS

Everest Interscience warrants each instrument to be free of defects in material or workmanship for a period of one year from the date of shipment to the original purchaser.

When examination of the instrument reveals that the fault has not occurred because of misuse or abnormal conditions of operation, Everest Interscience will service, replace or adjust any defective part or parts when the instrument is returned freight prepaid. ***OEM clients must show that recurring errors are not a part of the customer's assembly integration process. Upon the advice of Everest Interscience, certain malfunctions will be considered to be due to these process techniques and this warranty will be considered null and void for any instruments subjected to those methods.***

Instruments repaired when abnormal usage has occurred or beyond the effective date of the warranty will be charged at applicable rates. Everest Interscience will submit a quotation for the estimated charges before commencing repair. The customer must provide a Purchase Order or credit card information in the amount of the repair and return shipping before work will commence. After Everest has sent the repair quotation, the customer has up to one year to provide a Purchase Order or credit card information to Everest for either the repair and return or the return only of the instrument. If the customer does not provide this information within one year, Everest will recycle the instrument.

Instruments whose warranty expiration dates exceed five years from the current date may be subject to denial for service and repair. In such instances, please contact the Service & Repair Division at (520) 792-4545.

This warranty includes recalibration and battery replacement during the warranty period, if required.

NOTE: THE WARRANTY IS NULL AND VOID IF:

- The instrument has been dismantled, or***
- The instrument case has been deformed such as dented, gouged, tool marks are present, etc.***

If shipping from within the United States, please call 1-800-422-4342 for a Return Materials Authorization (RMA) number. Outside of the US, please call 1-520-792-4545. Then for the United States and all other countries, please ship the instrument insured, freight prepaid to:

EVEREST INTERSCIENCE, INC.
P. O. BOX 5276
TUCSON, AZ 85703-0276 USA

Please include a letter explaining the difficulty that you are having with the instrument, or complete the RMA Form provided to you, when returning the instrument for repair. An RMA Form can be downloaded from our website: <http://www.everestinterscience.com/Forms/rmarequest.htm>. It is necessary to send a check in the amount of the Evaluation Analysis Fee along with the instrument. This charge can be obtained on our RMA form on the website or by calling (800) 422-4342 or (520) 792-4545.

We apologize in advance if you do have a problem with one of our instruments. We will call you when we receive the instrument and before commencing any work on the instrument if repairs are necessary. Also, we will do all we can to repair it and return it to you as quickly as possible.

DETERMINATION OF EMISSIVITY

Introduction

Most organic materials and non-metallic materials whose surfaces appear to be rough and highly absorbent, have an emissivity of essentially 0.98 or a nearly perfect emittance characteristic. The materials cause few problems in making infrared temperature measurements. When the emissivity is less than the perfect 1.0, the user must know how to set the emissivity in order to compensate for the less efficient emission characteristics. The typical emissivities of known materials are presented in Table 1.

Emissivity Measurement

The emissivity of a surface may be measured by comparison of the infrared thermometer reading with a standard contact thermometer on the same surface.

A miniature, thin-film platinum resistance sensor is preferred for the contact sensor because it has a planar surface that makes better physical contact with the surface than a conventional probe. A conventional probe may be used if modest error is acceptable. Follow the manufacturer's recommendations for mounting any sensor to the test surface. The contact sensor should be as small as possible and bare (unhoused), for best results.

Once the contact sensor is intimately attached to the Surface Under Test (SUT) and measuring properly, elevate the temperature of the SUT and stabilize at a temperature near the upper end of the infrared thermometer's span for approximately one hour for thick sections and proportionately less for thin sections.

After stabilization, aim the infrared thermometer at a spot on the SUT as close as possible to the contact sensor. If your instrument has Visual Light Sighting, refocus the instrument until a ring configuration appears on the light spot. Position the contact sensor in the dead center section of the ring. Change the emissivity up or down until the infrared thermometer display reads the same as the contact thermometer following the instructions in the Operating Instructions portion of this Manual. The resulting emissivity reading is then equal to the emissivity of the SUT at that temperature and under those conditions. Record this reading for future reference.

Another simple method of determining emissivity values of greybody surfaces up to approximately 400°C is to mask off a portion of the base surface with masking tape or scotch tape and pass the area adjoining the tape edge through a candle flame or "smoky" torch to deposit hydrocarbon soot on the area to effect a complete coverage. This soot has a high, well defined emissivity of 0.955 ± 0.01 , and has better thermal conductivity and a thinner section than paint so as not to affect the thermal balance of the substrate. If the tape is now pulled off of the target, a sharp line will divide the soot-covered area from the bare area to be evaluated.

Heat the object to an appropriate temperature and, using an instrument with Light sighting with an emissivity setting of 0.95, measure the temperature of the soot area just adjacent to the bare material line. Next, move the instrument over to where the light is just on the bare surface adjacent to the boundary and adjust the emissivity control to produce the same temperature reading that you got on the soot-covered area. Record the value of this emissivity for future reference.

Emissivity of Total Radiation for Various Metals

MATERIAL	°C	EMISSIVITY
Alloys: Nicket-Chromium		
20Ni-25Cr-55Fe, Oxidized	200	0.90
60Ni-12Cr-28Fe, Oxidized	270	0.89
80Ni-20Cr	100	0.87
Aluminum:		
Polished	50-500	0.04-0.06
Rough Surfaces	20-50	0.06-0.07
Strongly Oxidized	55-500	0.2-0.3
Oxidized	200	0.11
Asbestos Boards	20	0.96
Bismuth, Oxidized	25	0.048
Brass:		
Dull, Tarnished	200	0.61
Oxidized @ 600°C	200	0.61
Unoxidized	25	0.035
Polished	200	0.03
Rolled Sheet	20	0.06
Carbon:		
Filament	1000-1400	0.53
Graphite	0-3600	0.7-0.8
Lamp Black	20-400	0.96
Soot Applied to Solid	50-1000	0.96
Soot with Water Glass	20-200	0.96
Unoxidized	100	0.81
Chromium, Polished	50	0.1
Cobalt, Unoxidized	500	0.13
Columbium, Unoxidized	1500	0.19
Copper:		
Calorized	100	0.26
Calorized, Oxidized	200	0.18
Commercial, Scoured to a Shine	20	0.07
Oxidized	50	0.6-0.7
Polished	50-100	0.02
Unoxidized	100	0.02
Unoxidized liquid	---	0.15
Fire Brick	1000	0.75
G-10 Epoxy Resin	---	0.95
Glass	20-100	0.94-0.91
Gold:		
Carefully Polished	200-600	0.02-0.03
Unoxidized	100	0.02
Enamel	100	0.37
Graphite	0-3600	0.7-0.8
Gypsum	20	0.93
Iron, Cast:		
Oxidized	200	0.64
Strongly Oxidized	40	0.95
Unoxidized	100	0.21
Unoxidized, Liquid	---	0.29
Rusted	25	0.65

Wrought, Dull	100	0.05
Lamp Black	25	0.94
Lead:		
Oxidized	200	0.96
Unoxidized	200	0.63
Mercury, Unoxidized	25	0.10
Molybdenum	600-1000	0.08-0.13
Monel, Metal Oxidized	200	0.43
Nichrom Wire:		
Clean	50	0.65
Oxidized	50-500	0.95-0.98
Nickel		
Industrial, Polished	200-400	0.07-0.09
Oxidized	200	0.37
Oxidized @ 600°C	200-600	0.37-0.48
Unoxidized	25	0.045
Platinum:		
Clean, Polished	200-600	0.05-0.1
Unoxidized	25	0.037
Unoxidized, Wire	50-200	0.06-0.07
Porcelain, Glazed	20	0.92
Quartz	---	0.92
Rubber:		
Hard	20	0.95
Soft, Grey, Rough	20	0.86
Silica Brick	1000	0.80
Silicon	---	0.92
Silver:		
Clean Polished	200-600	0.02-0.03
Unoxidized	100	0.02
Soot Applied to Solid Surface	50-1000	0.94-0.91
Soot with Water Glass	20-200	0.96
Steel:		
Alloyed (8% Ni, 18% Cr)	500	0.35
Aluminized	50-500	0.79
Dull Nickel Plated	20	0.11
Flat, Rough Surface	50	0.95-0.98
Cast, Polished	750-1050	0.52-0.56
Sheet, Ground	50	0.56
Oxidized	200-600	0.8
Calorized, Oxidized	200	0.52
Sheet with Shiny Layer Oxidized	20	0.82
Strongly Oxidized	50	0.88
Unoxidized	100	0.08
Unoxidized, Liquid	---	0.28
Tantalum, Oxidized	1500	0.21
Tungsten, Unoxidized	25	0.024
Varnish:		
Dull Black	40-100	0.8-0.95
Glossy Black Sprayed on Iron	20	0.87
Zinc:		
Polished	200-300	0.04-0.05